

# K-Series (KE, KM, KK) Constant-Wattage Heating Cable Installation Instructions

	<p>You must read and understand this manual before installing, operating, or servicing this product. Failure to understand these instructions could result in an accident causing serious injury or death.</p> <p>Keep these instructions for future reference.</p>
---	---

## TABLE OF CONTENTS

Introduction .....	2
Safety Alert Symbol .....	2
Important Safety Instructions.....	3
Connection/Termination Kits Descriptions.....	4
Prior to Installation .....	4
Lead Termination Preparation.....	5
End Termination Preparation .....	6
Power Input Connection Installation.....	7
Splice Installation .....	8
Heating Cable Installation .....	9
Testing.....	11
Troubleshooting Guide.....	14

## INTRODUCTION

Thank you for purchasing a BriskHeat K series constant-wattage heating cable system. A heating cable system is a combination of heating cable, connection/termination kits, temperature controller, and accessories based on your particular application. Your heater is designed to provide a long and efficient service life with function, reliability, and safety in mind.

All BriskHeat Constant-Wattage Heating Cable utilize a parallel resistance modular design. This allows the heating cable to be cut to length and terminated in the field, without affecting the heating power per unit length. The modular design enables the cable terminations/electrical connections to be made with cold leads and cold ends (e.g. cable not heated in electrical junction box).

A temperature controller is required for all constant-wattage heating cable.

For additional information concerning this, or other BriskHeat products, please contact your local BriskHeat distributor or contact us toll free (U.S. and Canada) at 1-800-848-7673 or 614-294-3376.



### SAFETY ALERT SYMBOL

The symbol above is used to call your attention to instructions concerning your personal safety. It points out important safety precautions. It means **“ATTENTION! Become Alert! Your Personal Safety is involved!”** Read the message that follows and be alert to the possibility of personal injury or death.



Immediate hazards which **WILL** result in severe personal injury or death.



Hazards or unsafe practices that **COULD** result in severe personal injury or death.



Hazards or unsafe practices that **COULD** result in minor personal injury or property damage.

**SAVE THESE INSTRUCTIONS!**  
Additional copies of this manual are available upon request.

**IMPORTANT SAFETY INSTRUCTIONS**



**⚠ DANGER**

A person who has not read and understood all operating Instructions is not qualified to operate this product.

**⚠ DANGER**

- Do not immerse heater in liquid.
- Keep volatile or combustible material away from heater when in use.
- Use heater only in approved locations
- Keep sharp metal objects away from heater.

Failure to observe these warnings may result in electric shock, risk of fire, and personal injury.

**⚠ WARNING**

- Only qualified personnel are allowed to connect the electrical wiring.
- Disconnect all supply power at the source before making any heating cable power input connections.
- All electrical wiring must follow local electrical codes and highly recommend following NEC Article 427.
- The person who performs the final installation / wiring must be qualified for this work.
- The end-user is responsible for providing a suitable disconnecting device.
- The end-user is responsible for providing suitable electrical protection device. It is highly recommended that a ground fault circuit breaker be used.

Failure to observe these warnings may result in personal injury or damage to the product and/or property.

**Agency Approvals**



Ordinary Locations  
Hazardous Locations  
Class I, Division 2, Groups B, C, & D  
Class II, Division 2, Groups F & G  
Class III, Division 2

Approvals valid only when installed in accordance with all applicable instructions, codes, and regulations.

**⚠ CAUTION**

- Never handle the heater while it is in operation; always disconnect the heater from the power source and allow to cool prior to handling.
- Inspect heater and connection kits before use.
- Never operate heater without a temperature control device.
- Do not wrap the heating cable over itself.
- If spillage of foreign matter onto heater occurs, disconnect from power source and clean after heater is allowed to cool.
- Never operate a heater without an appropriate heat sink (device being heated is considered a heat sink)
- Do not operate heater above rated temperature value.
- Fasten heater to device using approved methods only.
- Do not repair damaged or faulty heaters.
- Do not crush or apply severe physical stress on heater or cord assembly.
- Disconnect heater when not in use.

Failure to observe these warnings may result in personal injury or damage to the heater.

**CONNECTION / TERMINATION KIT DESCRIPTIONS**

**KCABUC:**

Universal Connection/Termination Kit

- 2-Lead pouches
- 2-End pouches
- 1-3 oz. Tube RTV sealant
- 1-Caution label
- 2-Ring terminals
- 2-Splice connector 12-10
- 2-Wire nuts
- 1-1" NPT Pipe standoff
- 2 Pipe straps

Enough to complete one power input connection or one power input splice, two lead terminations and two end terminations.

*NOTE: Requires Double-hub junction box.*

**KCABKC:**

Lead/ End Termination Kit

- 5-Lead pouches
- 5-End pouches
- 1-3 oz. Tube RTV sealant

Enough to complete five lead terminations and five end terminations.

**KCABSK:**

Splice Kit

- 3-Lead pouches
- 3-End pouch
- 1-3 oz. Tube RTV sealant
- 1-Caution label
- 3-Ring terminals
- 3-Splice connectors 12-10

Enough to complete one in-line splice or one tee splice, three lead terminations and three end terminations.

*NOTE: Requires single hub junction box, pipe standoff, two pipe straps.*

**KCABLP:**

Lead Termination Kit

- 1-Lead pouch

Enough to complete one lead termination.

*NOTE: Requires RTV silicon.*

**KCABEP:**

End Termination Kit

- 1-End pouch

Enough to complete one end termination.

*NOTE: Requires RTV silicone.*

**PRIOR TO INSTALLATION**

**STEP 1:**

Check for suspected damage to heater like rips, punctures, etc. Ensure surface to be heated is free of jagged or sharp edges or weld splatter.

**STEP 2:**

Confirm all necessary installation hardware and tools are readily available. Depending on the application and kit, this may include...

**Tools**

- |                               |                      |             |
|-------------------------------|----------------------|-------------|
| Diagonal Cutter               | Knife                | Screwdriver |
| Crimping Tool / Wire Stripper | Measuring Tape/Ruler |             |

**Hardware and Accessories**

- |  |                              |                        |
|--|------------------------------|------------------------|
| Temperature Controller                   | Monitor Light Kit (Optional) | Aluminum or Fiberglass |
| Temperature Sensor                       | RTV Sealant                  | Adhesive Tape (verify  |
| Connection / Termination Kits            | Pipe Straps                  | temperature rating)    |
| (see kit descriptions to verify contents | Junction Box                 | Heat Conductive Putty  |
| and additional required hardware)        | Wire Nuts                    | Pipe Standoffs         |
| Insulating Material                      | Caution Labels               | Pipe Reducer           |

**STEP 3:**

(A) Verify the total amperage of the system does not exceed the maximum amperage that the heating system components can handle. (B) Verify that the total length of cable required does not exceed the maximum circuit length. If the cable length exceeds (A) or (B), the cable must be divided into sections.

### LEAD TERMINATION PREPARATION

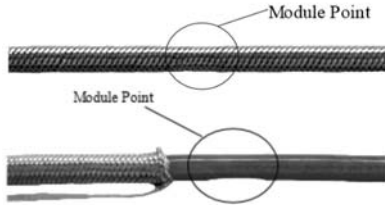

**STEP 1:**

Determine the module length of the heating cable. Module points can be identified by slight indentations on the rounded surface of the outer jacket. You can determine the module point by touch or visually by sliding back the metallic overbraid.

**NOTE:** KE series cable module points must be visually identified due to FEP outer jacket.



**STEP 2:**

Cut the cable between the module points for the desired length of cold lead. The length of "cold lead" must be at least 12" (30.5cm) but no longer than the module length minus 6" (15.2cm). The section of cable between the end of the cable and the first module point will be the cold lead. This section will be used for lead termination / power input connection.



**STEP 3A: (KE cable only)**

Using a knife, remove 10" (25.4cm) of the outer jacket, exposing the metallic braid. DO NOT DAMAGE THE BRAID.

**STEP 3B: (all K series cable)**

Push 6" (15.2cm) of the metallic overbraid back to expose the extruded jacket on the cable. Using a pair of Wire Cutters, cut off 4" (10.1cm) of the exposed cable.



**STEP 4:**

Pull the metallic braid back over the end of the cable. Push the cable through the side of the metallic braid. Twist the empty braid to form a pigtail lead and crimp a ring terminal on the end (see picture above). A crimp barrel can also be used to extend the ground (braid) to another 12 AWG ground wire.

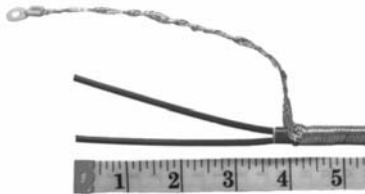

**STEP 5:**

Slide the metallic overbraid back at least an additional 4" (10.1cm). Using a knife, carefully cut and remove 4" (10.1cm) of the inner extruded jacket to expose the spirally wrapped resistance wire and the two bus wires. Do NOT damage the bus wires or the bus wire insulation; the resistance wire must NOT come into contact with the exposed bus wires. Unwrap and cut the resistance wire back to the point you cut the cable jacket.



**STEP 6:**

Fill a lead pouch with silicone RTV sealant. Slide the lead pouch over the two bus wires and over the inner wrap and outer most layer. Using wire strippers, remove 0.75" (1.9cm) of the insulation from the bus wires to expose the conductors.

DO NOT DAMAGE THE CONDUCTORS.

### END TERMINATION PREPARATION

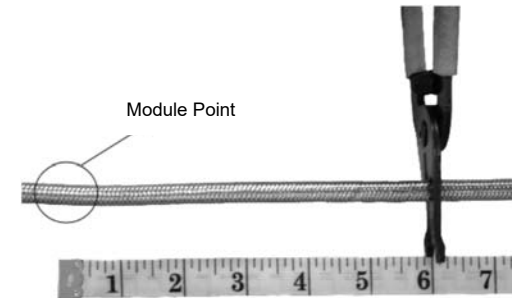

**STEP 1:**

Locate the last module point of the cable run. Cut the cable 6" (2.4cm) beyond this point to form a cold end.



**STEP 2A: (KE cable only)**

Using a knife, remove 2" (5cm) of the outer jacket, exposing the metallic braid. DO NOT DAMAGE THE BRAID.

**STEP 2B: (all K series cable)**

Using diagonal cutters and / or a knife, remove 1.5" (3.8cm) of the metallic braid and 1" (2.5cm) of the extruded jacket and inner wrap to expose the spirally wrapped resistance wire and the two insulated bus wires. Unwrap and cut off the resistance wire back to the inner jacket. Be careful not to damage the insulation on the bus wires. Cut one of the bus wires 0.5" (1.3cm) shorter than the other one. Make certain the resistance wire, the two bus wires, and the metallic braid do NOT contact each other.



**STEP 3:**

Fill an end pouch with silicone RTV sealant. Slide the filled end pouch over the two bus wires, inner jacket, and the outer most layer.

**Note:** When attaching the heating cable to the pipe, make sure that the last module point is in contact with the pipe surface.

**POWER INPUT CONNECTION INSTALLATION**

**⚠ WARNING**

Only authorized and trained personnel should perform the following procedure. The hazard of electrical shock exists with any electrical installation project. Disconnect all supply power at the source prior to making the heating cable power input connections.

**⚠ CAUTION**

A temperature controller is required for all constant-wattage heating cable.



**STEP 1:**

Prepare heating cable end as specified under "Lead Termination Preparation". Insert approximately 8" (20cm) of the heating cable(s) through the bottom of the cast aluminum pipe standoff, making sure the first module point stays in contact with the pipe.

**NOTE:** A maximum of three cables fit through pipe standoff.

**STEP 2:**

Place the standoff on the pipe surface at the point where the supply wiring and associated fittings will connect to the pipe heat tracing cable. Fasten the standoff to the pipe with pipe straps. Fill the top of the standoff with Silicone RTV to provide a moisture seal between the pipe and electrical junction box. Make certain there are no voids between the cable and pipe standoff. Allow an appropriate amount of time for the Silicone RTV to cure.

**STEP 3:**

Ensure the junction box chosen is equipped with a minimum of two 1" NPT female threaded hubs. Secure junction box onto the standoff. Pull the input power source wiring through the associated opening into the junction box. Connect the heating cable lead wires to a temperature controlling device and input power source wiring using wire nuts provided. Be sure to follow temperature controlling device installation instructions. If applicable, secure the braided pigtail ground to the standoff using the standoff ground screw provided or to the junction box using the junction box ground screw/receptacle. Ensure an adequate earth ground is provided to safely ground the entire assembly.



**SPLICE INSTALLATION**

**⚠ WARNING**

Only authorized and trained personnel should perform the following procedure. The hazard of electrical shock exists with any electrical installation project. Disconnect all supply power at the source prior to making the heating cable power input connections.

**STEP 1:**

Prepare the heating cable ends to be spliced together as specified under "Lead Termination Preparation".

**CAUTION:** Never connect the two parallel conductors of the heating cable together.

**STEP 2:**

Insert the heating cable cold leads up through the pipe standoff and into the junction box. Attach the pipe standoff and junction box to the pipe where the splice is to be located. Fasten it with appropriately sized pipe clamps.

**NOTE:** A maximum of three cables fit through pipe standoff.

**STEP 3:**

Connect the leads of the heating cable ends together using wire nuts as shown in the illustrations (wire nuts are not provided with KCABSK).

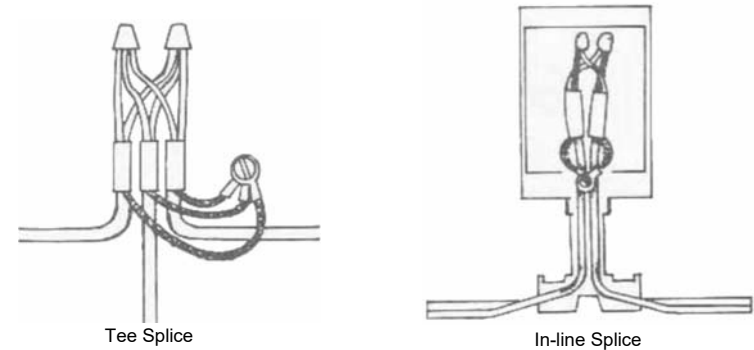

**STEP 4:**

Connect the terminal lugs on the braid leads to a grounded screw on the pipe standoff or on the junction box.

**NOTE:** The junction box and pipe standoff must be grounded.

**STEP 5:**

Test the cable installation for continuity and insulation resistance. The insulation resistance between the bus wires and the metallic braid must be greater than 50 megohms at 500 volts. Close the junction box and attach the Caution Label to the cover of the junction box.

**HEATING CABLE INSTALLATION**

**Cable Wrapping Techniques**

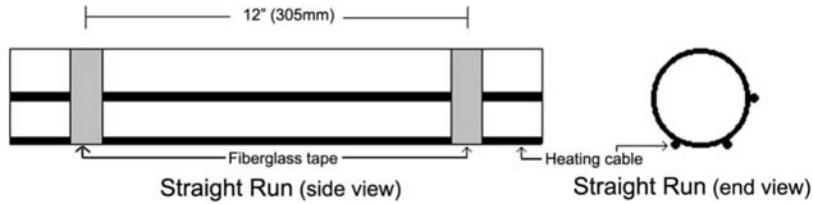

A straight run is the simplest method to installing heating cable. It is possible to have multiple straight runs on a single object. With a single straight run, position cable at the bottom of a horizontal pipe.

**⚠ CAUTION**

Do not wrap the heating cable over itself or have two heating cables touch.

All parts of heating cable must make intimate contact with surface to be heated.

Use heat conductive putty to fill voids between cable and pipe surface.

Wrap adhesive tape every 12" (305mm) around heating cable and pipe to attach the cable.

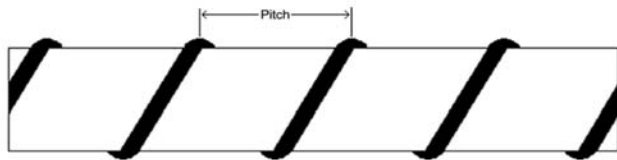

**Spiral wrap**

Spiral wrapping provides more heater coverage than a straight run. It can also require more heating cable. Verify the pitch length (see illustration) prior to installation to ensure you have enough heating cable to finish the job. If you need assistance in determining the pitch length, call your local distributor or BriskHeat<sup>®</sup>.

**⚠ CAUTION**

Do not wrap the heating cable over itself or have two heating cables touch.

All parts of heating cable must make intimate contact with surface to be heated.

Use heat conductive putty to fill voids between cable and pipe surface.

Wrap adhesive tape every 12" (305mm) around heating cable and pipe to attach the cable.

**Heating Cable Placement on Different Types of Objects**

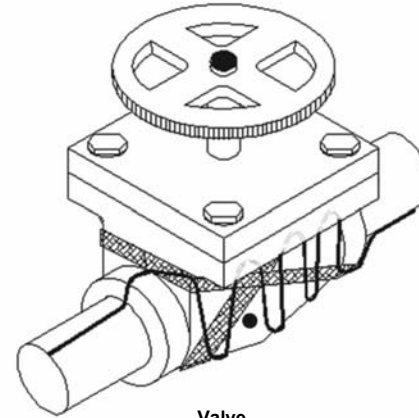

**Valve**

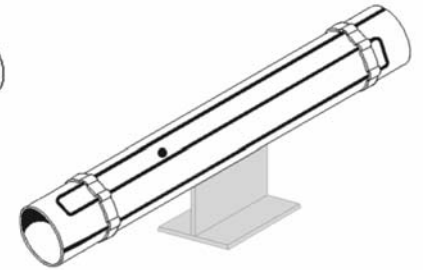

**Pipe Support**

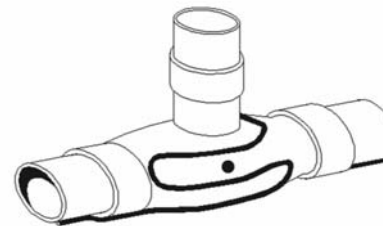

**Blind Tee**

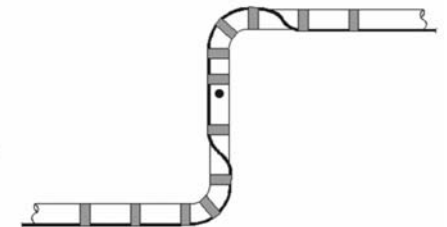

**Elbow**

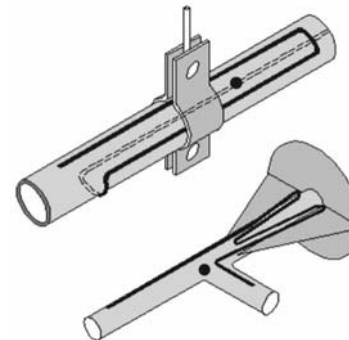

**Support**

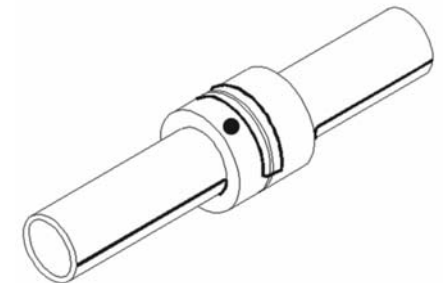

**Flange Body**

**TESTING**

Electrical tests are recommended at specific points in the receipt and installation of the heating cable. This periodical testing is designed to prevent the expenditure of wasted labor in the event of damage to the product. Installation costs of the cable and thermal insulation are much greater than the heating cable. Quick identification of any heating cable damage is the most economic approach to an installation. An insulation resistance test is recommended at the following point of the installation process:

- UPON RECEIPT of the heating cable
- BEFORE thermal INSULATION installation
- IMMEDIATELY AFTER thermal insulation installation
- As part of a PERIODIC MAINTENANCE program

The insulation resistance test is used to check for damage to extruded jackets. Connections for the megger are made as shown.

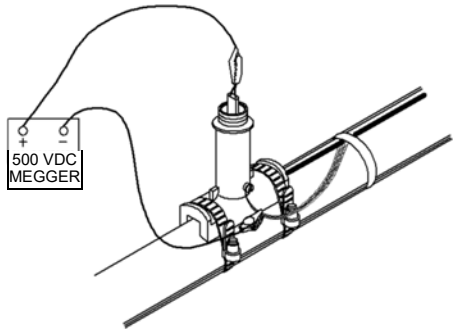

**FOR HEATING CABLES WITH BRAID**

Test from heating cable bus wires to braid.

*Note: Test should use at least a 500 VDC megger. Do not use a megger with an excess of 2500 VDC. Minimum acceptable readings should be 20 megohms per circuit, regardless of length.*

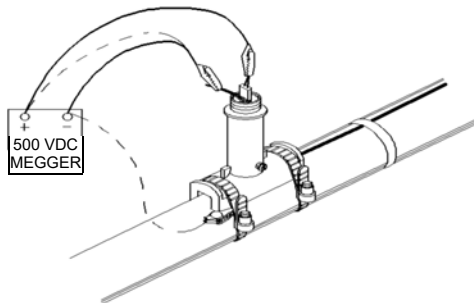

**FOR HEATING CABLES WITH BRAID AND OUTER JACKET**

Test A - (solid lines) from heating cable bus wires to braid.

Test B - (dotted lines) from braid to metal pipe.

A record should be kept of the readings taken from the time the cable is first installed on the pipe. A history of the insulation resistance reading can be helpful in spotting moisture ingress into the electrical system (indicated by a gradual decline in the insulation resistance) or physical damage to the heating cable (indicated by a sharp decline in the insulation resistance). A sample record for this is shown. (See the following page)

**BriskHeat Periodic Inspection Record**

The Periodic Inspection record Form may be used in one of two ways:

1. **One sheet per circuit** - The results of periodic tests of a single circuit are posted in vertical columns, beginning on the left and working toward the right. This allows easy comparison of test values for up to three test sequences on an individual circuit.
2. **One circuit per column** - Test data for a single test sequence on as many as three circuits can be recorded on a single sheet.

For additional Periodic Inspection Record Forms, contact your local distributor/representative or Briskheat at 1-800-848-7673 (toll free, U.S. / Canada) or 1-674-294-3376 (Worldwide) or [bhtsales1@briskheat.com](mailto:bhtsales1@briskheat.com).

Circuit Number
Heater Type
Circuit Length

<b>Freeze Protection Circuits -</b>			
Perform these checks as season requiring use approaches.			
<b>Temperature Maintenance Circuits -</b>			
Perform these checks at least twice per year.			

<b>Maintenance Checks for _____ Month _____ Year _____</b>				
Visual inspection inside connection box	Initial			
corrosion, moisture, etc.	Date			
Damage or cracks (leaks) in insulation	Initial			
seals at valves, hangers, pumps, etc.	Date			
Heating cable properly connected and grounded. heating cable and connections insulated from connection box.	Initial			
	Date			
Thermostat checked for moisture, corrosion, set point, switch operation, and capillary damage	Set Point			
	Initial			
	Date			
Megger tests performed at power connection with both bus wires disconnected from power wiring.	Reading			
	Initial			
	Date			
Circuit voltage at power connection.	Reading			
Circuit amperage after 5 minutes	Reading			
Pipe temperature at time amps were measured.	Reading			
Watts/Ft.				
<u>Volts x Amps</u> = w/ft.	Initial			
feet	Date			
All connections, boxes, and thermostats have been resealed.	Initial			
	Date			
End seals, covered splices and tees marked	Initial			
On insulation cladding.	Date			

Periodic Inspection Record Form

<b>Remarks &amp; Comments</b>			

**Periodic Inspection Record Form**

**TROUBLESHOOTING GUIDE**

Please read this guide prior to contacting BriskHeat<sup>®</sup>. This guide is designed to answer the most commonly asked questions. If you are unable to identify the problem or need additional assistance, please contact your local distributor/ representative or us at **1-800-848-7673, 614-294-3376**, or **bhtsales1@briskheat.com**.

PROBLEM	SOLUTION(S)
Entire heating cable run does not heat	Verify heater is connected to proper voltage.  Check to see if there is a resistance reading (not an open circuit) in heater using an ohm meter.
Portion of heating cable does not heat	Examine unheated module for damage.
Circuit breaker is tripping	Validate that the circuit breaker is capable of handling the amp requirement of heater.  Examine heater and power wiring for any damage.  Verify open circuit exists between bus wire and ground braid.  Ensure heater length does not exceed maximum circuit length.

**KE: Maximum Circuit Length in ft (m)**

Cable Type	120VAC	208VAC	240VAC	277VAC	480VAC
4 watts/ft (13 watts/m)	480 (146)	830 (253)	960 (293)	1110 (338)	1920 (585)
8 watts/ft (26 watts/m)	240 (73)	415 (127)	480 (146)	555 (169)	960 (293)
12 watts/ft (39 watts/m)	160 (49)	277 (85)	320 (98)	370 (113)	640 (195)

**KM: Maximum Circuit Length in ft (m)**

Cable Type	120VAC	208VAC	240VAC	277VAC	480VAC
4 watts/ft (13 watts/m)	480 (146)	830 (253)	960 (293)	1110 (338)	1920 (585)
8 watts/ft (26 watts/m)	240 (73)	415 (127)	480 (146)	555 (169)	960 (293)
12 watts/ft (39 watts/m)	160 (49)	277 (85)	320 (98)	370 (113)	640 (195)

**NOTES****KK: Maximum Circuit Length in ft (m)**

Cable Type	120VAC	208VAC	240VAC	277VAC	480VAC
4 watts/ft (13 watts/m)	480 (146)	830 (253)	960 (293)	1110 (338)	1920 (585)
8 watts/ft (26 watts/m)	240 (73)	415 (127)	480 (146)	555 (169)	960 (293)
12 watts/ft (39 watts/m)	160 (49)	277 (85)	320 (98)	370 (113)	640 (195)
18 watts/ft (59 watts/m)	105 (32)	185 (56)	215 (65)	245 (75)	425 (130)

**WARRANTY INFORMATION**

BriskHeat warrants to the original purchaser of this product for the period of eighteen (18) months from date of shipment or twelve (12) months from date of installation, whichever comes first. BriskHeat's obligation and the exclusive remedy under this warranty shall be limited to the repair or replacement, at BriskHeat's option, of any parts of the product which may prove defective under prescribed use and service following BriskHeat's examination, is determined by BriskHeat to be defective. The complete details of the warranty can be found online at [www.briskheat.com](http://www.briskheat.com) or by contacting us at 1-800-848-7673 (toll free, U.S. / Canada) or 1-614-294-3376 (Worldwide).



Corporate Headquarters:  
4800 Hilton Corporate Dr.  
Columbus, OH 43232, U.S.A.

Toll Free: 800-848-7673  
Phone: 614-294-3376  
Fax: 614-294-3807  
Email: [bhtsales1@briskheat.com](mailto:bhtsales1@briskheat.com)