



MPC Series

Digital Temperature Controllers

Installation Manual



Read and understand this manual before operating or servicing this temperature control system. Failure to understand how to safely operate these controllers could result in an accident causing serious injury or death. Only qualified personnel should operate or service these controllers.

TABLE OF CONTENTS

1. Shipment and Storage	03
2. Important Safety Instructions	04
3. Installation	05
a. Mounting the Controller	06
b. Power Input Connections	08
c. Alarm Dry Contact Connections	10
d. RS485 Communication Connections	10
4. Operation	11
5. Programming and Operation	12
6. Warranty	16

SHIPMENT AND STORAGE

Shipment

Each BriskHeat Temperature Controller is shipped in a box specially designed to protect the unit during shipment. The box containing the controller should be stored indoors in a dry, protected area. Under no circumstances should condensation, rain, snow or water be allowed to come in contact with the box or the controller while in storage.

Storage

Avoid storing the controller in places where:

- The ambient temperature may reach beyond the range of:
 - -40 to +80 °C (-40 to 176°F).
- The humidity conditions may go beyond:
 - 0 to 90% at 40 °C non-condensing
 - 10 to 50% at 55 °C non-condensing

IMPORTANT SAFETY INSTRUCTIONS

SAFETY ALERT SYMBOL



The symbol above is used to call your attention to instructions concerning your personal safety. It points out important safety precautions. It means “**ATTENTION!** Become Alert! Your Personal Safety is involved!” Read the message that follows and be alert to the possibility of personal injury or death.

DANGER

Immediate hazards which **WILL** result in severe personal injury or death

WARNING

Hazards or unsafe practices which **COULD** result in severe personal injury or death

CAUTION

Hazards or unsafe practices which **COULD** result in minor personal injury or property damage

DANGER

A person who has not read and understood all operating instructions is not qualified to operate

DANGER

- Do not immerse or spray any component of the temperature controller in liquid.
- Keep volatile or combustible material away from controller when in use.
- Keep sharp metal objects away from controller.

Failure to observe these warnings may result in electric shock, risk of fire, and personal injury.

CAUTION

- Inspect all components before use.
- Do not use controller if any component is damaged.
- Do not repair a damaged or faulty controller.
- Do not crush or apply severe physical stress on any component of system, including cord assembly.
- Unplug controller when not in use.

Failure to observe these warnings may result in personal injury or damage to the temperature controller.

WARNING

End User Must Comply to the Following:

- Only qualified personnel are allowed to connect electrical wiring
- All electrical wiring must follow local electrical codes and NEC Article 427
- Final installation/wiring is to be inspected by the authority who has jurisdiction in the area where the heater and temperature control system are installed
- The end-user is responsible for providing a suitable disconnect device
- The end-user is responsible for providing a suitable over-protection device. It is highly recommended that a ground-fault circuit breaker be used

INSTALLATION

It is recommended that the user read this manual in its entirety before installing or operating the temperature control system.

CAUTION

Unless otherwise specified, the controller's end user must supply branch-circuit protection and the disconnecting means.

General

BriskHeat temperature controllers are designed to operate from a single power input connection. Unless custom ordered, BriskHeat temperature controllers do not provide over current protection nor do they have the means of disconnecting power. The end user is responsible for the disconnecting means and branch circuit protection. It is highly recommended that the end user protect the controller with a GFCI, in case of ground-fault.

CAUTION

All electrical connections must be made by a qualified electrician in accordance to all applicable building regulations, electrical codes, and safety standards.

The controller should be installed indoors in an area that is dry and classified as a non-hazardous location.

Mounting the MPC Controller:

The following procedure should be used when installing the MPC temperature controller.

1. Choose an appropriate location considering the following:
 - a. Proximity to a suitable power supply.
 - b. Proximity to overcurrent protection.
 - c. Proximity to a means of disconnecting or switching equipment.
 - d. Appropriate clearances
 - i. *Example: clearance to open enclosure door at least 90°, clearance to allow easy connection of power cords and sensors*
 - e. Operating temperature does not go beyond the range of:
 - i. -10 to +55 °C (+14 to 131 °F)
 - f. Humidity conditions do not go beyond:
 - i. 0 to 90% up to 40 °C non-condensing, 10 to 50% at 55 °C non-condensing.
2. Mount the controller securely in the chosen location. All four mounting holes should be used and bolted to a strong stable support. The mounted location must provide easy access for the operator. The following drawings display the three different size enclosures that the MPC controllers will use. The drawings display the maximum exterior dimensions, mounting dimensions and recommended clearances needed for normal operation. Depending on the options that have been selected for the MPC controller, the enclosure size for a particular controller may actually be larger than displayed in this manual. In such cases, the customer should contact the factory for the specific enclosure size. (Actual dimensions may vary slightly in the field. All designs are subject to change without notification.)

Enclosure size for two to four zones:

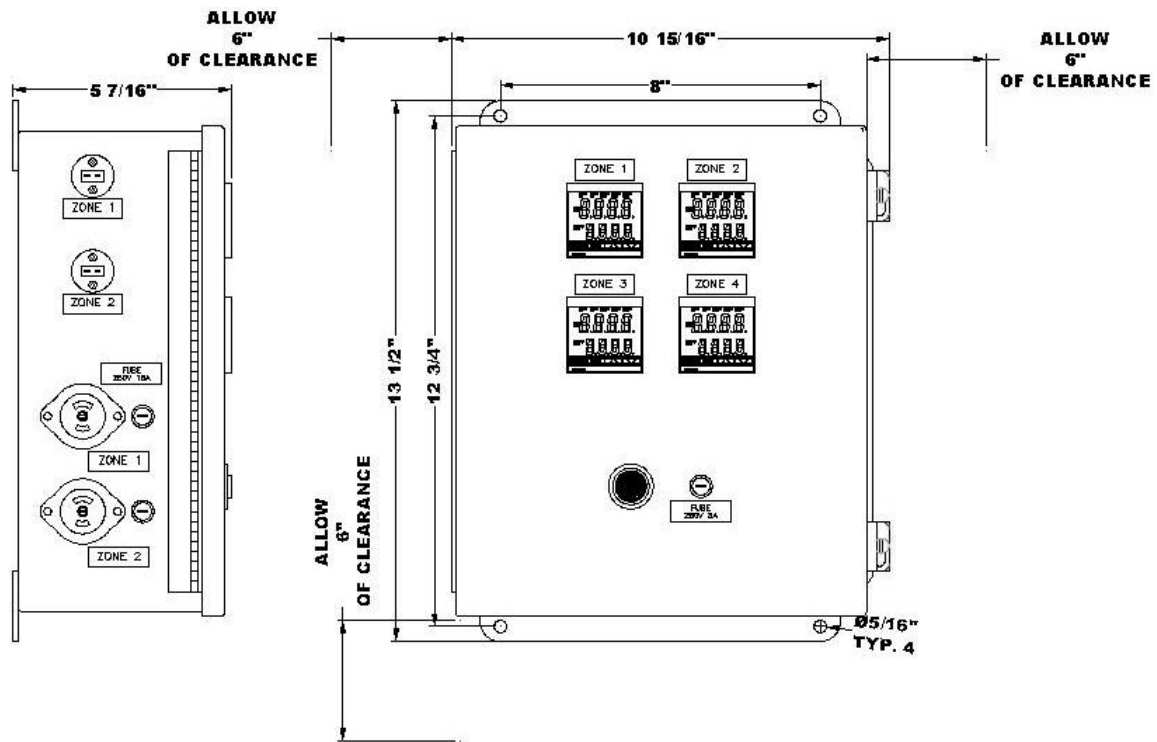

Enclosure size for five to eight zones:

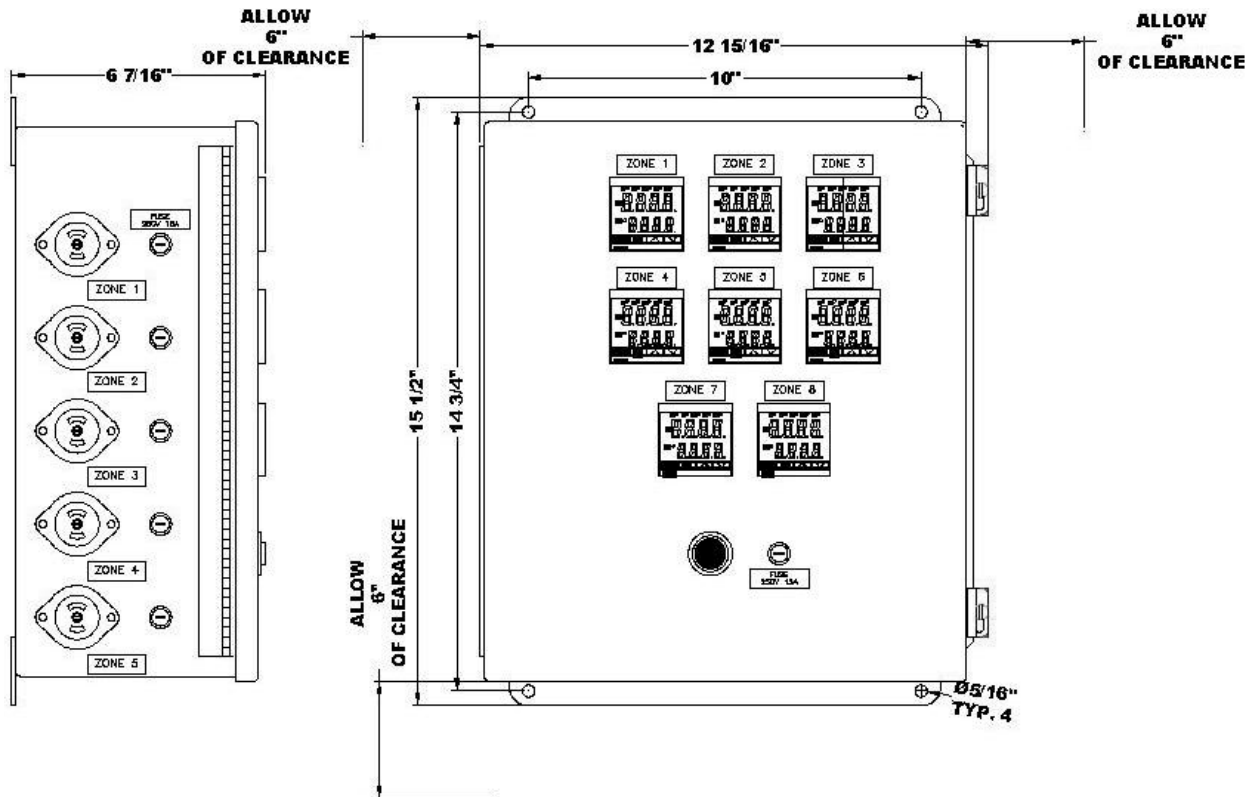

Enclosure size for nine to ten zones:

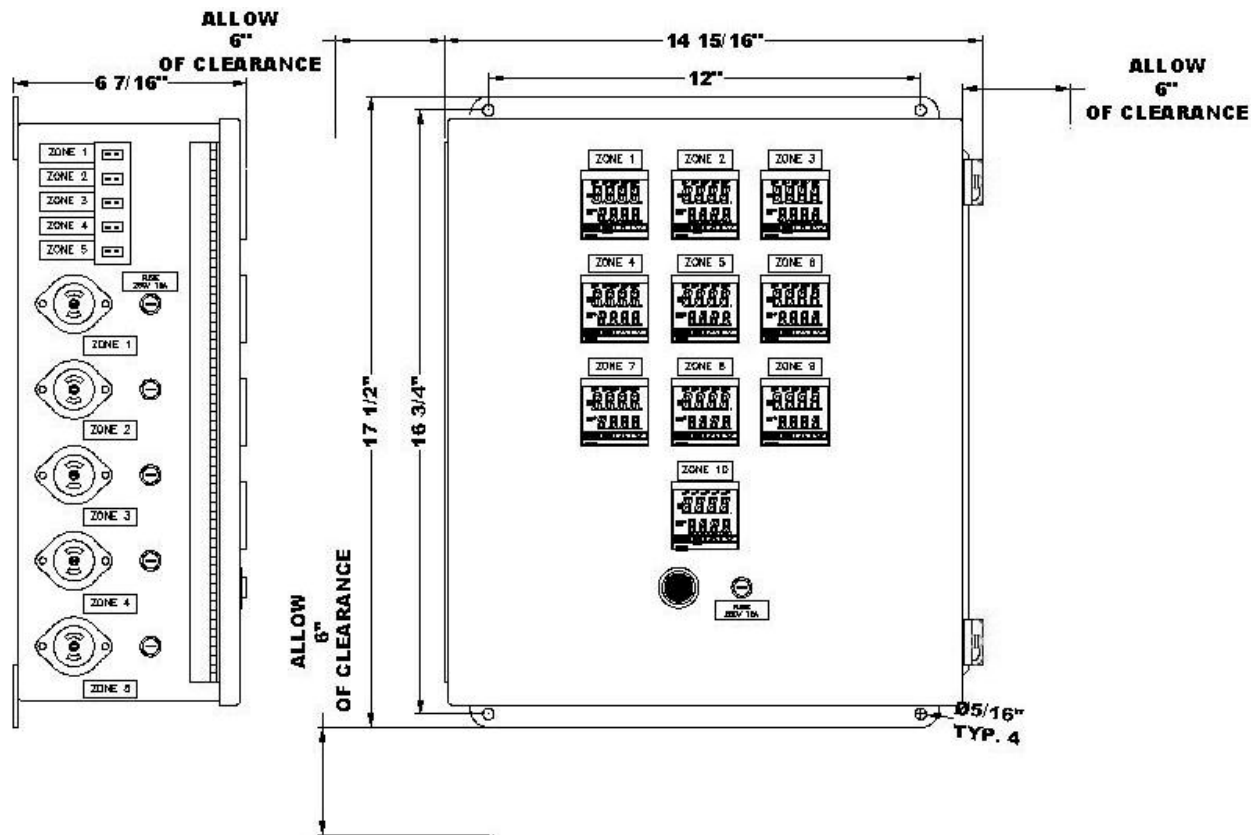

Power Input Connections:

Connect the power supply lines for the controller per the following drawings. The distribution block will be located in the bottom center of the inner panel. The installer should punch the appropriate sized hole to install the conduit for the input power

⚠ CAUTION

The hazard of electrical shock exists with any electrical installation. Disconnect all power routed to the controller at its source before making any internal connections. Check the controller’s data label or the electrical schematics for the required power supply necessary for your controller. A qualified electrician must make all electrical connections in accordance to all applicable building regulations, electrical codes, and safety standards.

Two to seven zone MPC single phase:

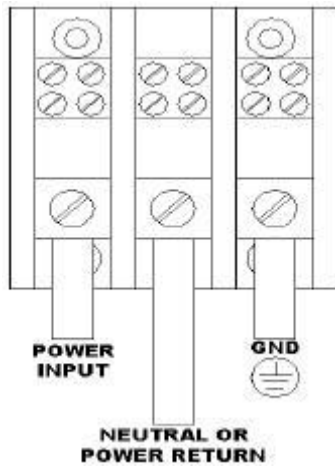

Eight to ten zone MPC single phase:

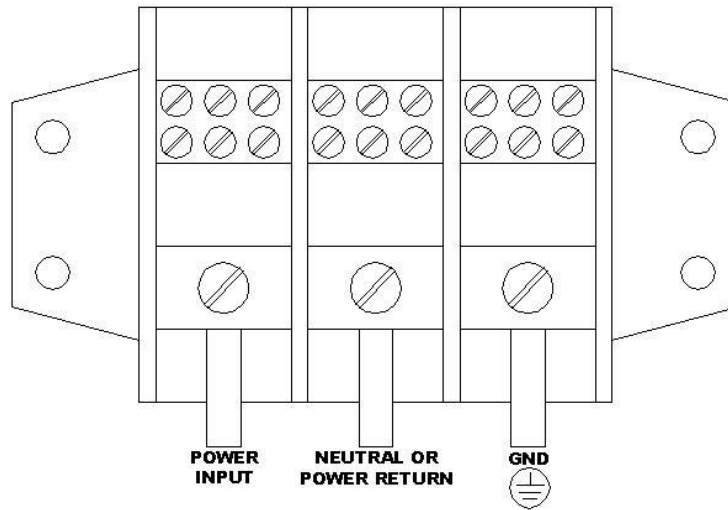

Two to seven zone MPC three phase:

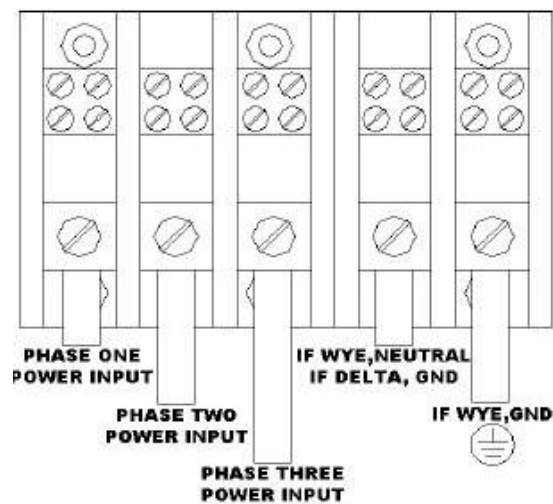

Eight to ten zone MPC three phase:

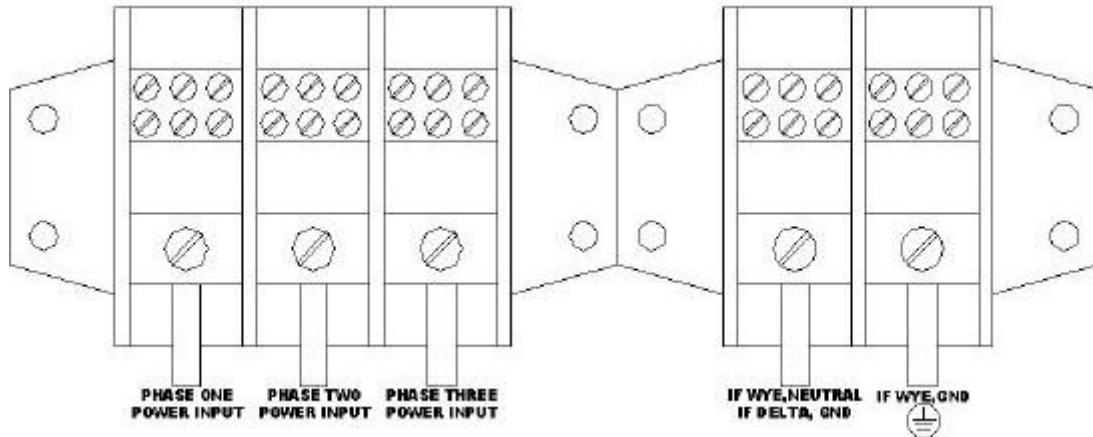

Alarm Dry Contact Connection:

The male receptacle pin layout is shown in Diagram A. The alarm contact is rated for 220VAC/30VDC at 1A (resistive load).

Diagram A:

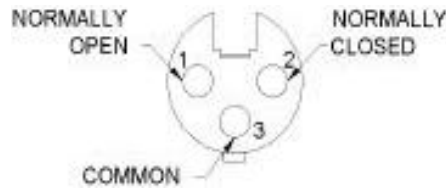

The alarm relay cable O.D. must be between 0.11” –0.315” with two to three 18 AWG conductors. The female connector pieces assemble together as shown in Diagram B.

Diagram B:

RS-485 Communications Connection

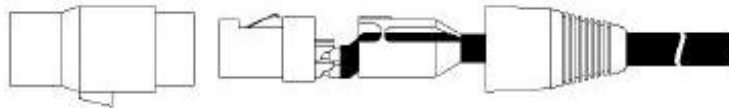

The female receptacle for the RS485 communications is connected as shown in Diagram C.

Diagram C:

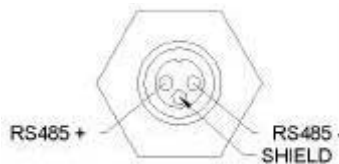

The communication cord must be less than 0.28” in diameter and contain two 20AWG conductors. The plug pieces assemble together as shown in the drawing Diagram D.

Diagram D:

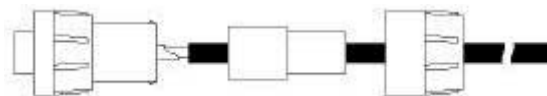

OPERATION

1. All MPC controllers use, “J” type thermocouples. The thermocouple jacks accept mini thermocouple plugs.
2. Place the thermocouple sensing tip between the surfaces to be heated and the heater to be controlled. The thermocouple tip must be placed in a location which best reflects the end user’s application. Depending on the object’s size and shape, there may be spots that are warmer or colder due to different thermal transfer parameters. If all areas of the object must reach a minimum temperature, then place the thermocouple tip on the coldest spot. If the temperature of any area of the object cannot go above the controller’s set point, then place the thermocouple tip on the hottest spot. If a temperature differential is allowable, then place the thermocouple tip on an area where the temperature is between the hottest and coldest.
3. Plug the power lead of the heater (s) into the appropriate zone receptacle.
4. Plug the thermocouple into the thermocouple jack that corresponds to the zone that it is measuring.
5. Push the green switch located on the front of the controller to the “ON” position. The green switch will latch into a recess position and will illuminate.
6. Program each zone controller with the values needed to properly control the heater. (See Programming and Operation *page12*)
7. It is highly recommended that the end user select the self-tuning for optimal performance. (See Programming and Operation *page12*)

PROGRAMING AND OPERATION

GETTING STARTED

The main steps to get started are shown below. For information on navigation through mode menus, refer to the menu flowchart shown overleaf.

1. Power up, a self-test procedure automatically starts, all LED segments and indicators will light up momentarily. On first power up **Goto Conf** will be displayed, indicating configuration is required. At all other times, the instrument returns to operator mode once the self-test procedure is complete.

2. Controller configuration

Set up inputs, output, alarms and function key operation via 'configuration mode' menu, see section 7

important: this must be completed before making changes to 'set-up mode' or other modes

3. Application set-up Change application specific settings in 'set-up' mode, see section 7.

4. Tune controller If PID control is required, tune the controller via 'Auto-tuning mode' mode menu.

Note: Auto-tuning will not engage if the proportional band = 0, the setpoint is ramping or if PV is within 5% of input span away from setpoint.

5. Operation mode: return to operation mode, the controller will now auto-tune.

MESSAGES AND ERROR INDICATION

These messages indicate that an error has occurred or there is a problem with the process variable signal or its wiring. The error indications are only an aid and do not remove responsibility for process safety from the operator or installer.

Caution: Do not continue with the process until any issue is resolved.

Parameter	Upper Display	Lower Display	Description
Instrument parameters are in default conditions	Goto	Conf	Configuration & Setup required. This screen is seen at first turn on, or if hardware configuration has been changed. Press OK to enter the Configuration Mode, next press ▲ or ▼ to enter the unlock code number, then press OK to proceed
Input Over Range	[HH]	Normal	Process variable input > 5% over-range
Input Under Range	[LL]	Normal	Process variable input > 5% under-range
Input Sensor Break	OPEN	Normal	Break detected in process variable input sensor or wiring
Warning Alarm	ALRN	Normal	Standard alarm, output latched alarm or diagnostic alarm active
Auto-tune running status	tunE	Normal	Indicates tuning is active
Profiler not running warning	n.run	Normal	Profiler not running because a segment target setpoint is not within the setpoint upper and lower limits.
Profiler running warning	[L]P	Normal	Profiler running and the setpoint upper or lower limit has been adjusted and the profiler active setpoint is now not within the setpoint upper and lower limits.
Profiler hold activated	hold	Normal	Profiler hold activated
Profiler Segment type	SGrt	Normal	Ramp time
Profiler Segment type	SGrP	Normal	Ramp rate
Profiler Segment type	SGdt	Normal	Dwell time
Profiler Segment type	StEP	Normal	Step
Profiler segment type	End	Normal	End

OPERATOR MODE

This mode is entered at power on, or accessed from Select mode (see section 2).

Note: All Configuration mode and Setup mode parameters must be set as required before starting normal operations.

Press **◀** to scroll through the parameters, then press **▲** or **▼** to set the required value.

Note: All Operator Mode parameters in Display strategy 6 are read only (see d, SP in configuration mode), they can only be adjusted via Setup mode.

Upper Display	Lower Display	Display Strategy and When Visible	Description
PV Value	Active SP Value	1 & 2 (initial screen)	PV and target value of selected SP <i>Local Setpoints are adjustable in Strategy 2</i>
PV Value	Actual SP Value	3 & 6 (initial screen)	PV and actual value of selected SP (e.g. ramping SP value). <i>Read only</i>
PV Value	(Blank)	4 (initial screen)	Process variable only <i>Read only</i>
Active SP Value	(Blank)	5 (initial screen)	Target value of selected setpoint only. <i>Read only</i>
SP Value	SP	1, 3, 4, 5 & 6	Target value of SP <i>Adjustable except in Strategy 6</i>
Actual SP Value	SPrP	SPr is not OFF	Actual (ramping) value of selected SP. <i>Read only</i>
Ramp Rate	rP	SPr enabled in Setup mode	SP ramping rate, in units per hour <i>Adjustable except in Strategy 6</i>
Active Alarm Status	ALSt	When one or more alarms are active. ALM indicator will also show on the upper display on the process variable screen.	<p>Alarm 2 active Alarm 1 active Loop Alarm active</p>
Warning alarm active	ALdG	These are the diagnostic alarms.	123i 1 = If output 1 actuations alarm active 2 = If output 2 actuations alarm active 3 = If output 3 actuations alarm active i = If Input is over ambient temperature
Latching output alarm active	ALOL	These are the output latching alarms.	OL1_ = Latching alarm 1 active OL_2 = Latching alarm 2 active OL12 = Latching alarm 1 and 2 lactive
Segment Number	SGnb	If Profile running	Current Segment number of active profile. <i>Read only.</i>
Target SP value	SGtS	If Profile Running	Target Setpoint of current Segment. <i>Read only</i>
Time remaining	SGtr	If Profile Running	Time remaining for current segment. <i>Read only.</i> <i>Format: MM.SS or HH.MM</i>
Cycles Remaining	cYcL	If Profile Running	Cycles remaining or INF for infinite. <i>Read only.</i>
Delay time remaining	dELY	If profiler started but not yet running.	Start delay time remaining. <i>Read only.</i>
Profiler reset	P_rSt	If profiler has ended and PrRE = COFF or PrRE = PnSP or PrER = COFF or PrER = PnSP or the user has stopped the profile from profiler control or the function key.	<p>Profiler reset. YES no</p> <p>When the display shows End a YES will reset the profiler and restore control or SP to the controller.</p> <p>If PrER = GCSP or PrRE = GCSP then End will only be shown for 30 seconds and this screen will not be shown.</p> <p>If the Func is set to Pct I then the user can use the function key as well to reset the profiler.</p>
Events Active	SGEA	If Profile Running and any events active	Shows numbers of Events Active.

Manual Control

If *Func* is set to *MAN* then manual control can be selected/de-selected by pressing **F** in the Operator mode.

While in Manual Control mode, the lower display will show *Pxxx* (where *xxx* is the current manual power level). Switching to/from manual mode is via Bumpless Transfer. Press **▲** or **▼** to set the required output power. **Caution: Manual power level is not restricted by the OPuL power limit.**

Profiler Control

If *Func* is set to *Profile* then the **F** key will operate the profiler as follows:

1. Profiler will run.
2. If the profiler is running – press the key, the profiler will hold.
3. If the profiler is running or in hold and you press the key for 5 seconds then the profiler will be stopped.
4. When the display shows *End* then pressing the key will remove the message and reset the profiler and restore control or SP to the controller if *PrrE* = *COFF* or *PrrE* = *MANSP* or *PrrE* = *COFF* or *PrrE* = *MANSP* or the user has stopped the profile from profiler control or the function key. If *PrrE* = *CCSP* or *PrrE* = *CCSP* then *End* will only be shown for 30 seconds and the key will clear if pressed but no profiler reset is activated.

Profiler configuration fast access

Press **☐** for 3 seconds to move to profiler configuration mode.

Software messages

If a process variable error occurs then software messages will be shown. If the process variable is ok then it will alternate with the highest priority software message active.

Message	Priority	Reason
<i>ALn</i>	1	Software alarm for loop alarm, alarm 1, alarm 2, latching alarm or diagnostics alarm.
<i>tunE</i>	2	Pre-tune active.
<i>hold</i>	3	Profiler hold activated.
<i>n run</i>	4	Profiler not running because a segment target setpoint is not within the setpoint upper and lower limits.
<i>CLiP</i>	4	Profiler running and the setpoint upper or lower limit has been adjusted and the profiler active setpoint is now not within the setpoint upper and lower limits.
<i>SGrt</i>	4	Profiler segment type ramp time.
<i>SGrP</i>	4	Profiler segment type ramp rate.
<i>SGdt</i>	4	Profiler segment type dwell time.
<i>StEP</i>	4	Profiler segment type step.
<i>End</i>	4	Profiler segment type end. If <i>PrrE</i> = <i>CCSP</i> or <i>PrrE</i> = <i>CCSP</i> then <i>End</i> will only be shown for 30 seconds.

Clearing Latched Output Alarms

Press **▲** or **▼** or 3 seconds on the *ALDL* screen.

If clearing a latched alarm and the same alarm is still active then the alarm will re-latch.

Latching alarms are cleared on a change of *LtPS* but if the same alarm is still active then the alarm will re-latch.

If the alarms are shown as latched on the display and the user changes the output usage not to include the latched alarm then the alarm latched will still be shown on the display until cleared.

NOTES:

WARRANTY INFORMATION

BriskHeat[®] warrants to the original purchaser for the period of eighteen (18) months from date of shipment or twelve (12) months from date of installation, whichever comes first. Contact factory at 1-800-848-7673 toll free, U.S. / Canada) or 614-294-3376 for complete details.

BriskHeat[®]
C o r p o r a t i o n

1055 Gibbard Avenue - Columbus, Ohio 43201

1-800-848-7673 (U.S. & Canada)

1-614-294-3376 (Worldwide)

w w w **.BriskHeat.** c o m

PN: 40890-08 REV A